

AirBrake® QDE, QDF, QDJ Bushing Mount Installation Instructions



Prior to installation please confirm that the following



- Qty(1) AirBrake® bushing mount assembly
- Qty(2) Shackle with screw pin
- Qty(6) Wire rope clips
- Qty(2) Thimble
- Qty(2) 1/2"-13 Eye bolt, washer, and nut
- Qty(3) Mount Bolts
- Qty(3) Lock washers
- Qty(2) Stainless steel restraining cable assembly
- Qty(2) Package of Loctite 262

CAUTION:

Prior to installation confirm the operation direction of the fan, and ensure this coincides with the direction of free rotation of the AirBrake®. Also ensure that the maximum overrunning speed does not exceed 600 RPM.

STEP 1:

NOTE:

Confirm there is no more than 0.5 inches (12.7 mm) of shaft extension beyond the bushing and that there is at least 3 inches (76.2 mm) of clearance between the bottom of the bushing and the nearest obstacle. On shafts greater than 2-15/16" (75 mm) in diameter there can be no shaft extension beyond the face of the bushing.

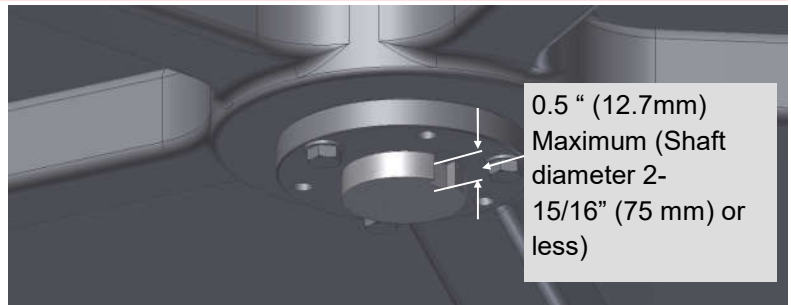

Figure 1. Maximum shaft extension.

STEP 2:

Install the AirBrake® assembly onto the bushing by aligning the installation holes of the AirBrake® assembly with the threaded holes of the bushing. Install the required hardware, bolt and lock washer, as shown in Figures 2 and 3 and torque the bolts to the values specified in Table 1.

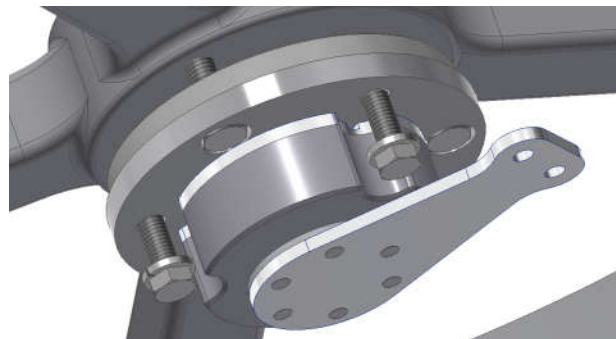

Figure 2. E, F, and J installation

STEP 3:

Insert the thimble portion of the cable assembly onto each shackle. Apply Loctite 262 to the threads of the screw pin of each shackle. Install both shackles onto the arm of the AirBrake® assembly with the head of the screw pin on the upper part of the shackle.

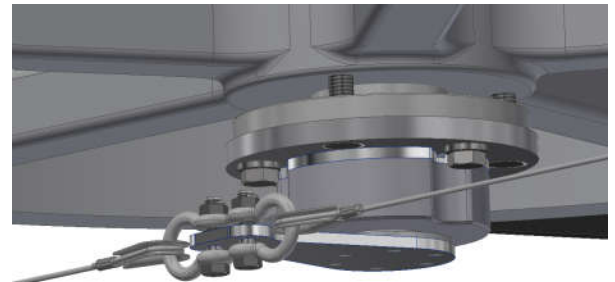

Figure 3. Installation of shackle

STEP 4:

Attach the supplied 1/2"-13 eye bolts to nearby suitable supports using supplied lockwashers and nuts. Each eye bolt should be as near to straight line opposite each other as possible (see **Figure 4**). Effectively creating an imaginary line through the junction of the double cable link bar center point with the AirBrake® arm. While 180° is the optimum cable placement, it is allowable for the cables to form as small an angle as 90° on the plane of the AirBrake® arm. Secure the free ends of the restraining cables to the eyebolts by first inserting one of the supplied thimbles through each eye bolt. Pass each cable around its associated thimble and secure with three wire rope clips on each cable. See **Figure 5** for proper rope clip installation. Ensure that the attachment of the cable to the support will not make the cable more than plus or minus 10° out of level as illustrated in **Figure 6**. Remove as much slack as practical from each cable. However, cables should NOT be taut. Apply Loctite 262 (or equivalent) to the threads of the rope clips and tighten the clips.

Table 1. Torque values for installation bolts.

QD Bushing Size	Torque
SF	50 ft-lbs (6.9 kg-m)
E	60 ft-lbs (8.3 kg-m)
F	75 ft-lbs (10.4 kg-m)
J	135 ft-lbs (18.7 kg-m)

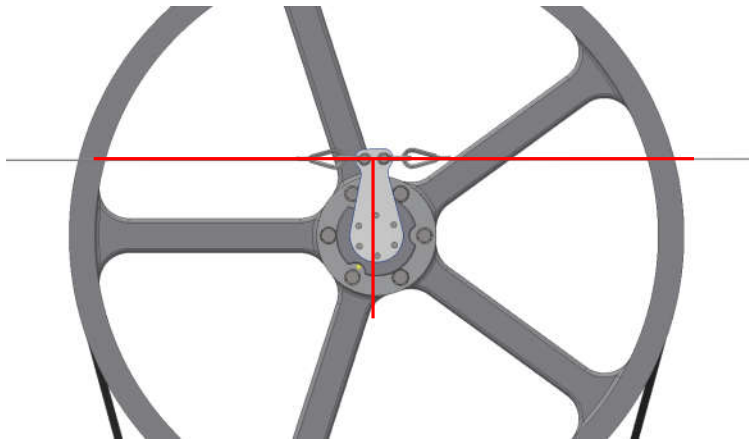

Figure 4.

STEP 5.

After installation of the restraining cables, check by hand for free rotation of the fan in the normal direction. Then, again by hand, attempt to rotate the fan in the backwards direction and ensure the AirBrake® is working properly. In the normal rotation direction of the fan, it is likely that both cables will be very slightly slack. In the backwards direction one cable should be taut. Ensure that neither cable may be in contact with any edge or surface (moving or stationary) which might lead to fraying and failure of the cable.

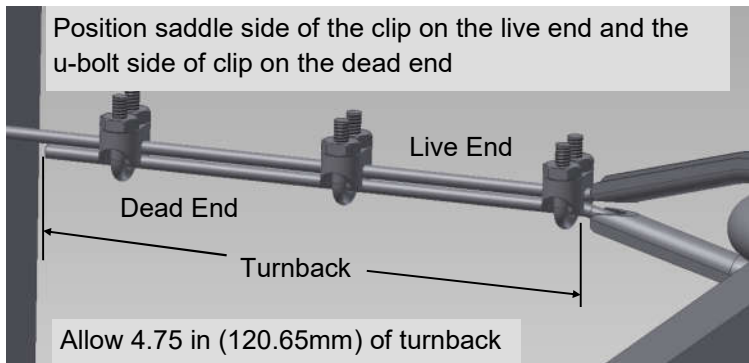

Figure 5. Proper installation of wire rope clips.

STEP 6.

Install all required guards and confirm there is sufficient clearance for the AirBrake® .

STEP 7.

After all of the necessary guards have been installed, run the fan at full speed, ensure that the cables are not overly tight and are positioned properly with all things working correctly.

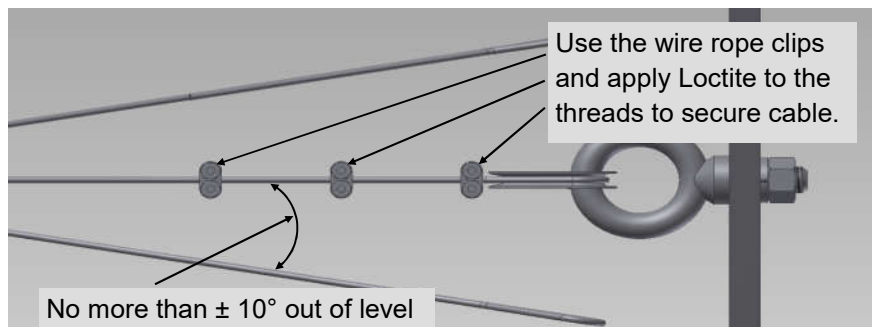

Figure 6. Restraining cable angle tolerance.